



LYNGSOE ERGO BIN™

THE 3RD GENERATION HIGH-CAPACITY, ERGONOMIC BIN FOR MATERIAL HANDLING IN LIBRARIES

MODERN AND SLEEK DESIGN

The super sleek Lyngsoe Ergo Bin™ has a high-end, slim, and light design. We know many libraries have the need for high capacity destinations for AMH sorter solutions, and also want a bin as a stand-alone unit in the library as an easily accessible drop-off point next to the self-service kiosk – with the full bin functionality. The bin construction is robust and built to handle the heavy load day in and day out.

EASY AND ERGONOMIC TO USE

The Ergo Bin is designed and built to give you a high-capacity bin that functions autonomously, no matter if you are filling or emptying the bin. Together with the design, this ensures a correct ergonomic work position for the staff.

Operation of the bin is simple and intuitive and controlled by the intelligent control board, both when the bin is docked and connected to the sorter, or when it operates as standalone disconnected from the sorter module. The user interaction is the same as operating the Lyngsoe Ergo Cart™, which makes it very easy and familiar for the staff to master.

LESS IS MORE

We know how much the footprint size of a sorting system means. So we have designed a bin that is compact and takes up minimal space and still has an amazing 161L/42.5 gal in material volume. We even use the same docking station as the one used for our Ergo Cart, giving more for less cost.

FLEXIBILITY

Different times of the day, different days of the week, or seasonal events, all have different capacity needs. But do not worry, as this is part of our design and gives you the freedom to choose among a Lyngsoe Ergo Cart, Lyngsoe Ergo Bin, Lyngsoe Metal Bin™, or the Lyngsoe Tote as a destination without the need to do any modification at all to the sorting system. Even the docking station for charging and connection to the sorter system is the same.

BENEFITS

- 161L/42.5 gal high-capacity volume
- Connected or standalone operation
- Fully autonomous or manual control
- Easy and ergonomic to use
- Small compact footprint
- Automatic charging
- Full flexibility of destination type



SPECIFICATIONS

LYNGSOE ERGO BIN™

GENERAL

Functions	Fill or Empty mode, Automatic operation of bin floor, Manual operation of bin floor, Pause/Resume fill mode, Visual Load indicator
Control panel	Simple intuitive built-in control panel (also used for Lyngsoe Ergo Cart™)
LED indicator	Connected/Ready for fill, Paused fill mode, Low battery, Charging battery, battery status
Sorter connection	Multi-purpose docking station (also used for Lyngsoe Ergo Cart™) for "Bin present" indication
Operational mode	Connected to sorter, and stand-alone operation
Charging	Automatic via docking station when connected to sorter module, and via wall-plug charger
Handlebar	Fixed handlebar. Option for adjustable ergonomic handlebar (extra cost).
Safety	Safety-key avoiding unauthorized use
Service	Service hatch for battery pack replacement

TECHNICAL INFORMATION

Load capacity	161L / 42.5 gal
Color	Back panel: Black (RAL 9005) Front panel: Black (RAL 9005) Side panels: Green (RAL 6025). Handlebar: Black (RAL 9005)
Dimensions	582 x 766 x 849 mm / 22.9 x 30.2 x 33.4" (W x D x H) excl. handlebar
Castors	100 mm, lockable back wheels
Wiring	All inside
Input voltage	24V / 100-240V AC 50-60 Hz
Battery	NiHM, 24V battery pack
Certificates	CE

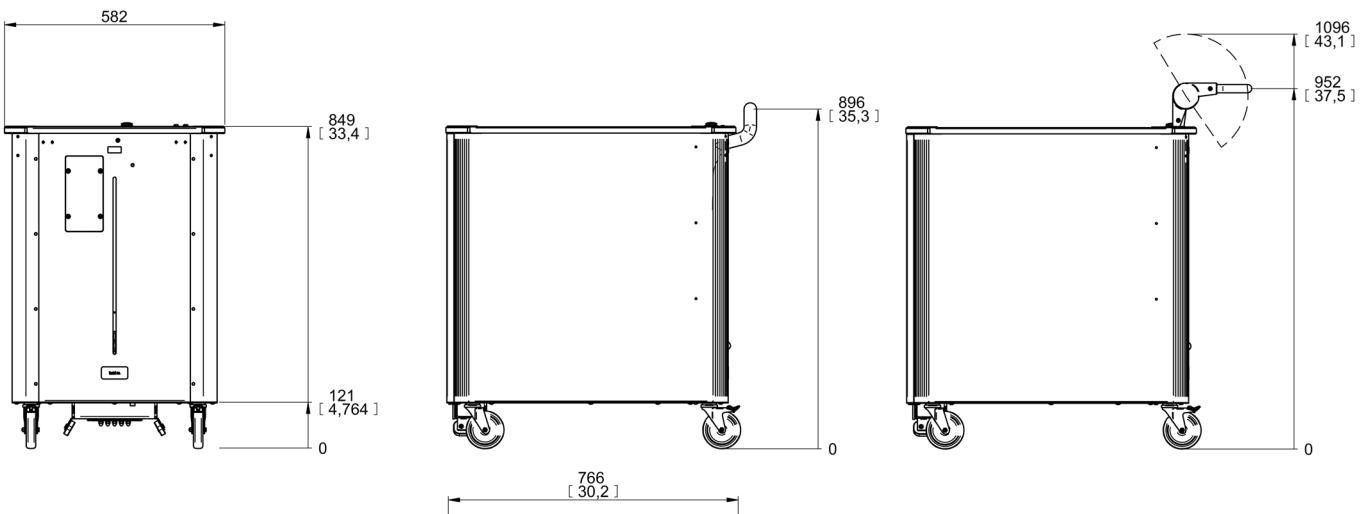

www.lyngsoesystems.com
library@lyngsoesystems.com

